



INTERNATIONAL APPLICATION PUBLISHED UNDER THE PATENT COOPERATION TREATY (PCT)

<p>(51) International Patent Classification ⁷ : B65D 33/00</p>	<p>A1</p>	<p>(11) International Publication Number: WO 00/26100 (43) International Publication Date: 11 May 2000 (11.05.00)</p>
<p>(21) International Application Number: PCT/US99/25046 (22) International Filing Date: 25 October 1999 (25.10.99) (30) Priority Data: 09/182,146 29 October 1998 (29.10.98) US (71) Applicant: HEALTHSHIELD TECHNOLOGIES L.L.C. [US/US]; 67 Prospect Avenue, Suite 201, West Hartford, CT 06106 (US). (72) Inventors: STAHL, Amy; 518 Park Drive, Boston, MA 02215 (US). BARRY, John, E.; 18 Drake Lane, Derry, NH 03038 (US). TROGOLO, Jeffrey, A.; 228 Commonwealth Avenue, Boston, MA 02116 (US). (74) Agents: GOGORIS, Adda, C. et al.; Darby & Darby P.C., 805 Third Avenue, New York, NY 10022-7513 (US).</p>		<p>(81) Designated States: AE, AL, AM, AT, AU, AZ, BA, BB, BG, BR, BY, CA, CH, CN, CR, CU, CZ, DE, DK, DM, EE, ES, FI, GB, GD, GE, GH, GM, HR, HU, ID, IL, IN, IS, JP, KE, KG, KP, KR, KZ, LC, LK, LR, LS, LT, LU, LV, MD, MG, MK, MN, MW, MX, NO, NZ, PL, PT, RO, RU, SD, SE, SG, SI, SK, SL, TJ, TM, TR, TT, UA, UG, UZ, VN, YU, ZA, ZW, ARIPO patent (GH, GM, KE, LS, MW, SD, SL, SZ, TZ, UG, ZW), Eurasian patent (AM, AZ, BY, KG, KZ, MD, RU, TJ, TM), European patent (AT, BE, CH, CY, DE, DK, ES, FI, FR, GB, GR, IE, IT, LU, MC, NL, PT, SE), OAPI patent (BF, BJ, CF, CG, CI, CM, GA, GN, GW, ML, MR, NE, SN, TD, TG).</p> <p>Published <i>With international search report.</i></p>
<p>(54) Title: ANTIMICROBIAL PLASTIC CLOSURES FOR DRINKING CONTAINERS</p>		
<p>(57) Abstract</p>		
<p>A closure for a container for liquids made of a resin containing an inorganic antimicrobial agent which can come into contact with the liquid.</p>		

FOR THE PURPOSES OF INFORMATION ONLY

Codes used to identify States party to the PCT on the front pages of pamphlets publishing international applications under the PCT.

AL	Albania	ES	Spain	LS	Lesotho	SI	Slovenia
AM	Armenia	FI	Finland	LT	Lithuania	SK	Slovakia
AT	Austria	FR	France	LU	Luxembourg	SN	Senegal
AU	Australia	GA	Gabon	LV	Latvia	SZ	Swaziland
AZ	Azerbaijan	GB	United Kingdom	MC	Monaco	TD	Chad
BA	Bosnia and Herzegovina	GE	Georgia	MD	Republic of Moldova	TG	Togo
BB	Barbados	GH	Ghana	MG	Madagascar	TJ	Tajikistan
BE	Belgium	GN	Guinea	MK	The former Yugoslav Republic of Macedonia	TM	Turkmenistan
BF	Burkina Faso	GR	Greece	ML	Mali	TR	Turkey
BG	Bulgaria	HU	Hungary	MN	Mongolia	TT	Trinidad and Tobago
BJ	Benin	IE	Ireland	MR	Mauritania	UA	Ukraine
BR	Brazil	IL	Israel	MW	Malawi	UG	Uganda
BY	Belarus	IS	Iceland	MX	Mexico	US	United States of America
CA	Canada	IT	Italy	NE	Niger	UZ	Uzbekistan
CF	Central African Republic	JP	Japan	NL	Netherlands	VN	Viet Nam
CG	Congo	KE	Kenya	NO	Norway	YU	Yugoslavia
CH	Switzerland	KG	Kyrgyzstan	NZ	New Zealand	ZW	Zimbabwe
CI	Côte d'Ivoire	KP	Democratic People's Republic of Korea	PL	Poland		
CM	Cameroon		Republic of Korea	PT	Portugal		
CN	China	KR	Kazakstan	RO	Romania		
CU	Cuba	KZ	Kazakstan	RU	Russian Federation		
CZ	Czech Republic	LC	Saint Lucia	SD	Sudan		
DE	Germany	LI	Liechtenstein	SE	Sweden		
DK	Denmark	LK	Sri Lanka	SG	Singapore		
EE	Estonia	LR	Liberia				

ANTIMICROBIAL PLASTIC CLOSURES FOR DRINKING CONTAINERS

Field of the Invention

The present invention relates to containers, such as baby bottles and cups, used for drinking purposes and closures for these articles.

5

Background of the Invention

It is always desirable to improve the sanitary properties of drinking containers. A particular object in this area would be to improve sanitary conditions of containers used by children and babies for drinking purposes. Typical among these are, for example, plastic baby bottles and drinking cups.

10

A typical baby bottle includes the bottle container itself and a closure formed by a rubber nipple and a collar of plastic material having a hole into which the nipple is inserted, with the collar being fastened to the container. Another typical type of such container is a plastic cup having a closure in the form of a lid with a spout, with the lid being screwed or snapped onto the cup. The plastic collar and the lid forming the closures are often made by injection molding.

15

Tests have shown that in products of this type, even a thin layer of milk residue on the baby bottle collar or cup lid left after coming into contact with the milk and then rinsed off in tap water, will support the growth of many kinds of bacteria. These bacteria multiply with time. A similar problem can arise in the lid of the cup, particularly in the spout which is hard to clean. Bacterial growth sites also can be produced by other liquids, such as fruit juices, formula, and even water. When the user drinks liquid from the bottle or cup, the liquid can come into contact with the bacteria, which can be transferred to the user. Accordingly, it would be

20

desirable to attempt to eliminate the growth of such bacteria on such products, that is to make the sites incapable or less capable of supporting bacterial growth.

Brief Description of the Invention

5 The present invention relates to closures of the type described above containing an inorganic antimicrobial agent, preferably a ceramic zeolite. In accordance with the invention, the container closures, such as the collar for the baby bottles and the lids for the cups, are made with the antimicrobial agent incorporated into the plastic resin used for molding the closures. Any food residue, such as milk, which comes into contact with the container closure made of such
10 material containing the inorganic antibiotic agent, has the bacteria therein killed, or substantially eliminated or reduced from what was present before. Therefore, the bacteria producing site is eliminated or growth of bacteria at the site is reduced.

Objects of the Invention

15 It is therefore an object of the present invention to provide plastic closures for drinking containers which incorporate an inorganic antimicrobial agent.

A further object is to provide closures for baby bottle and juvenile drinking containers having an antimicrobial agent.

20 Still a further object is to provide plastic closures for drinking containers containing an inorganic antimicrobial agent which reduce the possibility of establishment of bacterial growth sites.

Brief Description of the Drawings

25 Other objects and advantages of the present invention will become more apparent upon reference to the following specification and annexed drawings in which:

Fig. 1 is a perspective view of a collar for a baby bottle;

Fig. 1A is a plan view of an insert of antimicrobial material for a baby bottle collar;

30 Fig. 2 is a perspective view of a drinking container and a lid therefore;

Fig. 3 is a view of the underside of the lid of Fig 2 showing a modified

version thereof; and

Fig. 3A is a cross-section of a ridge used for the underside of the lid of Fig. 3.

Detailed Description of the Invention

5 Fig. 1 shows a collar 10 of the type used as a part of a closure for the open end of a baby bottle (not shown). The collar 10 has a top wall 12 with a hole 14 through which the end of the nipple (not shown) is inserted. The collar has a depending skirt wall 16 with threads on the inner wall thereof which are used to fasten the collar to the bottle with the nipple inserted. The collar 10 is made of a plastic material such as, for example, polypropylene, by any suitable process, such as injection molding. The flange of the nipple is held between the top end the bottle and the top wall 12 of collar. In general; milk leaks into the interface between the nipple flange and the collar. If the collar is not sterilized, but is only rinsed in tap water, there is a problem of possible growth of bacteria on the collar inner surface, as discussed above. Liquid passing over such a site can pick up the bacteria and carry it to the child in the liquid being drunk.

10

15

 Fig. 2 shows a portion of a conventional type of drinking cup 20 used by children. The cup has a threaded upper end 22 onto which the internally threaded wall 28 of a lid 30 is to be screwed. The lid 30 has a spout 32 which the child places in his/her mouth, tips the cup and drinks from it. Like the collars 10, the lids 20 also are of plastic and are typically made by injection molding. Here also, once milk or other liquid comes into contact with the inner surface of the top of the lid 30 and the spout 32 the lid is normally only rinsed in tap water, such that a film is present on these surfaces which can support the growth of bacteria. This is a particular problem in the spout area, which is hard to clean. As in the case of the bottle collar, liquid passing over these sites of bacterial growth can pick up bacteria, which will be transmitted to the child. Further, the potential problem is even more severe in containers of this type since they are used by children above the age of babies, e.g., toddlers, and therefore it is considered that it is not necessary to sterilize the lids. Also, the bacteria growing site on the surface of the lid is substantially larger than that of a bottle collar.

20

25

30

In accordance with the invention, the collar and lid components are made of material that has antimicrobial properties. It is preferred that the plastic resin used for forming the components contains an inorganic antimicrobial agent. A preferred inorganic antimicrobial agent that can be incorporated into a resin suitable for the products is an antibiotic zeolite. Suitable zeolites and a method for
5 incorporating them into the resin is disclosed in U.S. patent 4,938,955. The resins can be those such as polyethylene, polypropylene, polystyrene, polyvinyl chloride, ABS resins and others disclosed in said patent. The zeolite is kneaded into the resin and the composite of the resin and the zeolite are then processed, such as by injection molding, to form the articles 10 and 20 described above. The agent is
10 available on the potential bacteria growth sites of the surfaces of the articles, including the interior of the spout 32, to prevent the growth of bacteria, such as would be caused by milk and other liquids coming into contact with it. Other antimicrobial agents are also suitable as described below and would be processed in the same manner with the resin.

15 As for the inorganic antimicrobial agent incorporated in the resin, a number of metal ions, which are inorganic materials, have been shown to possess antibiotic activity, including silver, copper, zinc, mercury, tin, lead, bismuth, cadmium, chromium and thallium ions. These antibiotic metal ions are believed to exert their effects by disrupting respiration and electron transport systems upon
20 absorption into bacterial or fungal cells. Antimicrobial metal ions of silver, gold, copper and zinc, in particular, are considered safe even for *in vivo* use. Antimicrobial silver ions are particularly useful for *in vivo* use due to the fact that they are not substantially absorbed into the body. That is, if such materials are used they should pose no hazard.

25 In one embodiment of the invention, the inorganic antibiotic metal containing composition is an antibiotic metal salt. Such salts include silver iodate, silver iodide, silver nitrate, and silver oxide. Silver nitrate is preferred. These salts are particularly quick acting, as no release from ceramic particles is necessary for antimicrobial function.

30 Antibiotic zeolites are preferred. These have been prepared by replacing all or part of the ion-exchangeable ions in zeolite with ammonium ions and

antibiotic metal ions, as described in U.S. Patent Nos. 4,938,958 and 4,911,898. Such zeolites have been incorporated in antibiotic resins (as shown in U.S. Patent Nos. 4,938,955 and 4,906,464) and polymer articles (U.S. Patent No. 4,775,585).

Polymers including the antibiotic zeolites have been used to make refrigerators, dish washers, rice cookers, plastic film, chopping boards, vacuum bottles, plastic pails, and garbage containers. Other materials in which antibiotic zeolites have been incorporated include flooring, wall paper, cloth, paint, napkins, plastic automobile parts, catheters, bicycles, pens, toys, sand, and concrete. Examples of such uses are described in US Patents 5,714,445; 5,697,203; 5,562,872; 5,180,585; 5,714,430; and 5,102,401. These applications involve slow release of antibiotic silver from the zeolite particles which is suitable for the articles disclosed.

Antibiotic ceramic particles useful with the present invention include zeolites, hydroxy apatite, zirconium phosphates or other ion-exchange ceramics. Zeolites are preferred, and are described in the preferred embodiments referred to below. Hydroxy apatite particles containing antimicrobial metals are described, e.g., in U.S. Patent No. 5,009,898. Zirconium phosphates containing antimicrobial metals are described, e.g., in U.S. Patent Nos. 5,296,238; 5,441,717; and 5,405,644.

Antibiotic zeolites are well-known and can be prepared for use in the present invention using known methods. These include the antibiotic zeolites disclosed, for example, in U.S. Patent Nos. 4,938,958 and 4,911,898.

Either natural zeolites or synthetic zeolites can be used to make the antibiotic zeolites used in the present invention. "Zeolite" is an aluminosilicate having a three dimensional skeletal structure that is represented by the formula: $XM_2/nO \cdot Al_2O_3 \cdot YSiO_2 \cdot ZH_2O$. M represents an ion-exchangeable ion, generally a monovalent or divalent metal ion, n represents the atomic valency of the (metal) ion, X and Y represent coefficients of metal oxide and silica respectively, and Z represents the number of water of crystallization. Examples of such zeolites include A-type zeolites, X-type zeolites, Y-type zeolites, T-type zeolites, high-silica zeolites, sodalite, mordenite, analcite, clinoptilolite, chabazite and erionite. The present invention is not restricted to use of these specific zeolites.

The ion-exchange capacities of these zeolites are as follows: A-type

zeolite = 7 meq/g; X-type zeolite = 6.4 meq/g; Y-type zeolite = 5 meq/g; T-type zeolite = 3.4 meq/g; sodalite = 11.5 meq/g; mordenite = 2.6 meq/g; analcite = 5 meq/g; clinoptilolite = 2.6 meq/g; chabazite = 5 meq/g; and erionite = 3.8 meq/g. These ion-exchange capacities are sufficient for the zeolites to undergo ion-exchange with ammonium and antibiotic metal ions.

5 The specific surface area of preferred zeolite particles is preferably at least 150 m²/g (anhydrous zeolite as standard) and the SiO₂/Al₂O₃ mol ratio in the zeolite composition is preferably less than 14, more preferably less than 11.

 The antibiotic metal ions used in the antibiotic zeolites should be retained on the zeolite particles through an ion-exchange reaction. Antibiotic metal
10 ions which are adsorbed or attached without an ion-exchange reaction exhibit a decreased bacteriocidal effect and their antibiotic effect is not long-lasting. Nevertheless, it is advantageous for imparting quick antimicrobial action to maintain a sufficient amount of surface adsorbed metal ion.

 In the ion-exchange process, the antibiotic metal ions tend to be
15 converted into their oxides, hydroxides, basic salts etc. either in the micropores or on the surfaces of the zeolite and also tend to deposit there, particularly when the concentration of metal ions in the vicinity of the zeolite surface is high. Such deposition tends to adversely affect the bacteriocidal properties of ion-exchanged zeolite.

20 In an embodiment of the antibiotic zeolites, a relatively low degree of ion exchange is employed to obtain superior bacteriocidal properties. It is believed to be required that at least a portion of the zeolite particles retain metal ions having bacteriocidal properties at ion-exchangeable sites of the zeolite in an amount less than the ion-exchange saturation capacity of the zeolite. In one embodiment, the
25 zeolite employed in the present invention retains antimicrobial metal ions in an amount up to 41% of the theoretical ion-exchange capacity of the zeolite. Such ion-exchanged zeolite with a relatively low degree of ion-exchange may be prepared by performing ion-exchange using a metal ion solution having a low concentration as compared with solutions conventionally used for ion exchange.

30 The antibiotic metal ion is preferably present in the range of from about 0.1 to 20wt.% of the zeolite. In one embodiment, the zeolite contains from

0.1 to 20wt.% of silver ions and from 0.1 to 20wt.% of copper or zinc ions. Although ammonium ion can be contained in the zeolite at a concentration of about 20 wt.% or less of the zeolite, it is desirable to limit the content of ammonium ions to from 0.5 to 15 wt.%, preferably 1.5 to 5 wt.%. Weight% described herein is determined for materials dried at temperatures such as 110°C, 250°C or 550°C as this is the temperature employed for the preferred post-manufacturing drying process.

A preferred antibiotic zeolite is type A zeolite containing either a combination of ion-exchanged silver, zinc, and ammonium or silver and ammonium. One such zeolite is manufactured by Shingawa, Inc. under the product number AW-10N and consists of 0.6% by weight of silver ion-exchanged in Type A zeolite particles having a diameter of about 2.5 μ . Another formulation, AJ-10N, consists of about 2% by weight silver ion-exchanged in Type A zeolite particles having a diameter of about 2.5 μ . Another formulation, AW-80, contains 0.6% by weight of silver ion-exchanged in Type A zeolite particles having a diameter of about 1.0 μ . Another formulation, AJ-80N, consists of about 2% by weight silver ion-exchanged in Type A zeolite particles having a diameter of about 1.0 μ . These zeolites preferably contain about between 0.5% and 2.5% by weight of ion-exchanged ammonium.

The zeolites are often obtained in master batches of low density polyethylene, polypropylene, or polystyrene, containing 20 wt.% of the zeolite. Thus, they can be easily mixed with the resins used as thermoplastic materials for forming the composite resin used to make the articles of the invention.

The antibiotic particles are preferably present in a concentration by weight in the resin used to make the articles of from 0.01 to 10.0 wt%, more preferably from 0.01 to 8.0 wt%, and most preferably from 0.1 to 5.0 wt%.

The antibiotic properties of the antibiotic zeolite particles of the invention may be assayed while in aqueous formulations using conventional assay techniques, including for example determining the minimum growth inhibitory concentration (MIC) with respect to a variety of bacteria, eumycetes and yeast. In such a test, the bacteria listed below may be employed:

Bacillus cereus var mycoides,
Escherichia coli,
Pseudomonas aeruginosa,
Staphylococcus aureus,
Streptococcus faecalis,
5 *Aspergillus niger,*
Aureobasidium pullulans,
Chaetomium globosum,
Gliocladium virens,
Penicillium funiculosum,
10 *Candida albicans, and*
Saccharomyces cerevisiae.

The assay for determining MIC can be carried out by smearing a solution containing bacteria for inoculation onto a plate culture medium to which a test sample of the encapsulated antibiotic zeolite particles is added in a particular concentration, followed by incubation and culturing of the plate. The MIC is
15 defined as a minimum concentration thereof required for inhibiting the growth of each bacteria.

Safety and biocompatibility tests were conducted on the antibiotic zeolites employed in the invention. ISO 10993-1 procedures were employed. The

following results were obtained:

	Cytotoxicity: Non-Toxic
	Acute Systemic Toxicity: Non-Toxic
5	Intracutaneous Toxicity: Passed
	Skin Irritation Test: Non-Irritant
	Chronic Toxicity: No Observable Effect
	<i>In-vitro</i> Hemolysis: Non-Hemolytic
	30-day Muscle Implant Test: Passed
	60-day Muscle Implant Test: Passed
10	90-day Muscle Implant Test: Passed
	Ames Mutagenicity Test: Passed
	Pyrogenicity: Non-Pyrogenic

Thus, the antibiotic zeolites are exceptionally suitable under relevant
15 toxicity and biocompatibility standards for use in the articles and are not adversely
affected or deteriorated upon being contacted by beverages such as milk and fruit
juices.

Fig. 1A shows a product useful with a baby bottle in the form of an
annular disk 50 having a central hole 52 made from the resin and antimicrobial
20 agent mixture. Here, the mixture is formed into flat sheets which are then cut or
punched to the desired shape. The disks 50 also can be made by extrusion or
other conventional processes. Here, instead of making the entire collar 10 out of
the resin mixed with the antimicrobial agent, the disk 50 is inserted against the
inner surface of the collar upper wall 14. The agent present in the disk performs
25 the function of preventing bacteria growth, as explained above.

Fig. 3 shows the inner surface 35 of the lid 30 as having a plurality of
ridges 37 disposed thereon. The ridges 37 increase the available surface area of
the antibiotic agent. Fig. 3A shows the ridges 37 as being of generally triangular
shape, although other suitable shapes can be used.

30

WE CLAIM:

1 1. A closure for a container for holding a liquid, said closure formed
2 to cover at least a part of the opening of the container and having a surface area
3 which can be contacted by the liquid, said closure surface area comprising a resin
4 containing an inorganic antimicrobial agent.

1 2. A closure as in claim 1 wherein the entirety of said closure is
2 formed of said resin containing said inorganic antimicrobial agent.

1 3. A closure as in claim 1 wherein said closure comprises a collar to
2 be attached to the open end of a bottle, said collar having a top wall with a central
3 opening through which a nipple is to project, said surface to be contacted by the
4 liquid being the inner surface of said top wall.

1 4. A closure as in claim 3 wherein said surface to be contacted
2 comprises a disk of said resin containing said inorganic antimicrobial agent
3 opposing said top wall inner surface.

1 5. A closure as in claim 1 wherein said closure comprises a lid to be
2 attached to the open end of a container with said lid having a top wall with an
3 opening, said surface to be contacted being the inner surface of said lid top wall.

1 6. A closure as in claim 5 wherein said lid top wall opening
2 comprises a spout and said surface to be contacted further comprises the interior of
3 said spout.

1 7. A closure as in claim 6 wherein said closure and spout are of
2 integral one piece construction of said resin containing said inorganic antimicrobial
3 agent.

1 8. A closure as in claim 1 wherein said agent is an antibiotic metal

1 containing composition that imparts substantial antimicrobial action.

1 9. The closure of claim 8 wherein said inorganic antibiotic metal
2 comprises antibiotic ceramic particles comprising said metal.

1 10. The closure of claim 9 wherein said ceramic particles are selected
2 from the group consisting of zeolite, hydroxy apatite, and zirconium phosphate.

1 11. The closure of claim 8 wherein said inorganic antibiotic metal
2 containing composition comprises a silver salt.

1 12. The closure of claim 11 wherein said silver salt is selected from
2 the group consisting of silver iodate, silver iodide, silver nitrate, and silver oxide.

1 13. The closure of claim 12 wherein said silver salt is silver nitrate.

1 14. The closure of claim 9 wherein said antibiotic ceramic particles
2 comprise antibiotic zeolite prepared by replacing all or part of the ion-exchangeable
3 ions in zeolite with an antibiotic metal ion.

1 15. The closure of claim 8 wherein said antibiotic metal is selected
2 from the group consisting of silver, copper, zinc, and gold.

1 16. The closure of claim 8 wherein said antibiotic metal is silver.

1 17. The closure of claim 1 wherein said inorganic antimicrobial agent
2 comprises from 0.25% to 10.0% by total weight of the resin and agent.

1 18. The closure of claim 1 wherein said antibiotic agent is in particle
2 form and the size of said particles is from 0.25 to 10.0 microns.

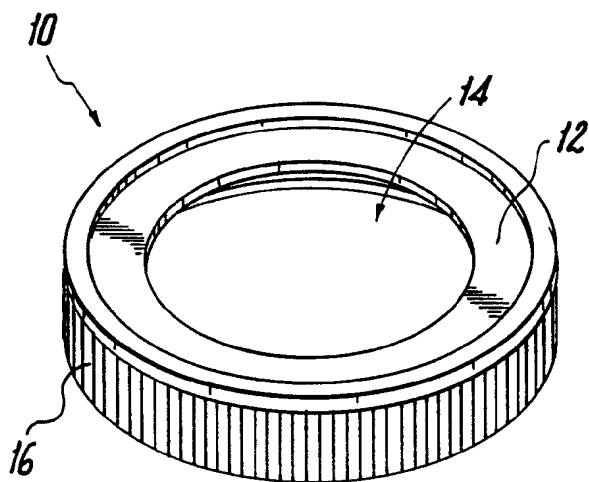

Fig. 1

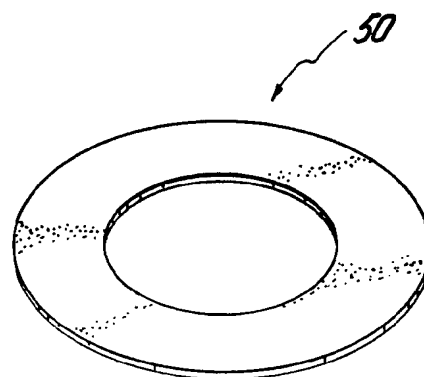

Fig. 1A

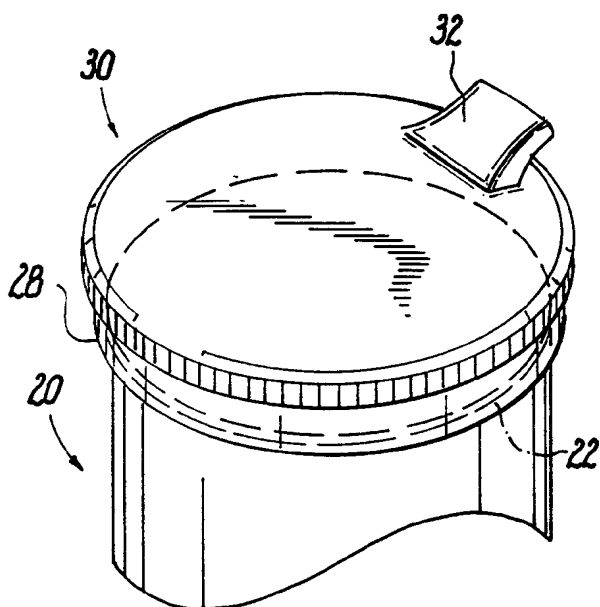

Fig. 2

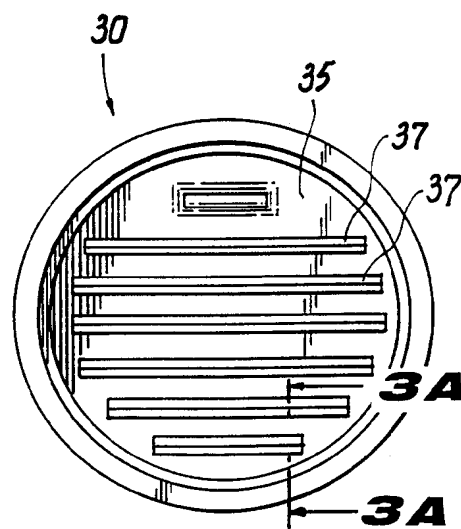

Fig. 3

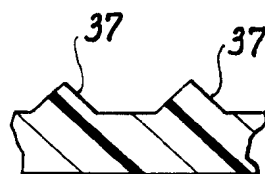

Fig. 3A

INTERNATIONAL SEARCH REPORT

International application No.

PCT US99 25046

A. CLASSIFICATION OF SUBJECT MATTER

IPC(7) :B65D 33/00

US CL :428/64.1, 66.3, 66.4; 215/341

According to International Patent Classification (IPC) or to both national classification and IPC

B. FIELDS SEARCHED

Minimum documentation searched (classification system followed by classification symbols)

U.S. : 428/64.1, 66.3, 66.4; 215/341

Documentation searched other than minimum documentation to the extent that such documents are included in the fields searched

Electronic data base consulted during the international search (name of data base and, where practicable, search terms used)

C. DOCUMENTS CONSIDERED TO BE RELEVANT

Category*	Citation of document, with indication, where appropriate, of the relevant passages	Relevant to claim No.
X --- Y	US 4,485,064 A (LAURIN) 27 November 1984, col. 3, lines 38-60.	1, 2, 8, 11-13, 15 & 16 ----- 3-7, 17 & 18
X --- Y	US 5,542,557 A (KOYAMA et al) 06 August 1996, col. 12, lines 20-25 and col. 13, lines 25-27.	1, 8-12 & 14-17 ----- 3-7, 13 & 18

Further documents are listed in the continuation of Box C. See patent family annex.

* Special categories of cited documents:	*T* later document published after the international filing date or priority date and not in contact with the application but cited to understand the principle or theory underlying the invention
A document defining the general state of the art which is not considered to be of particular relevance	*X* document of particular relevance, the claimed invention cannot be considered novel or cannot be considered to involve an inventive step when the document is taken alone
E earlier document published on or after the international filing date	*Y* document of particular relevance, the claimed invention cannot be considered to involve an inventive step when the document is combined with one or more other such documents, such combination being obvious to a person skilled in the art
L document which may throw doubts on priority claim(s) or which is cited to establish the publication date of another citation or other special reason (as specified)	*A* document member of the same patent family
O document referring to an oral disclosure, use, exhibition or other means	
P document published prior to the international filing date but later than the priority date claimed	

Date of the actual completion of the international search

03 DECEMBER 1999

Date of mailing of the international search report

21 JAN 2000

Name and mailing address of the ISA/US
Commissioner of Patents and Trademarks
Box PCT
Washington, D.C. 20231

Facsimile No. (703) 305-3230

Authorized officer

ALEXANDER S. THOMAS

Telephone No. (703) 308-2351